

Columbia Research Laboratories, Inc. **General Purpose Accelerometers**

Models 5011 & 5011-HT

- *Vibration & Shock
- *Sensitivity 4.5 pC/g
- *Low Base Strain Sensitivity
- *Electrically Isolated
- *10-32 Removable Stud

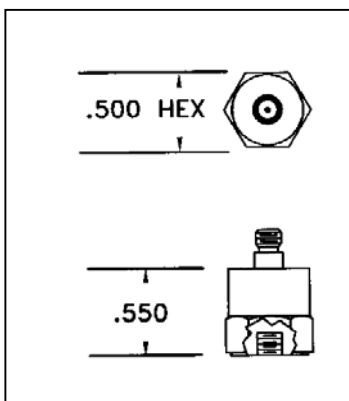
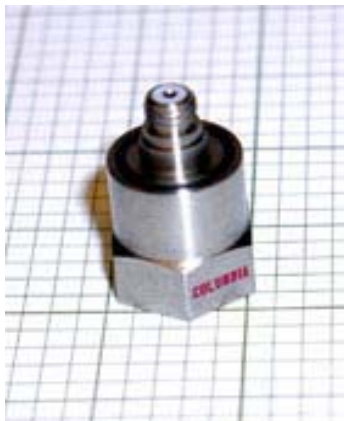

Accessories Supplied:

- (1) Miniature Cable Assembly, LNHT-10'
- (1) 10-32 x 0.375"L Mounting Stud, St Stl
- (1) Hardwood Storage Case
- (1) Standard Calibration Data
- (1) Manufacturers Certificate of Compliance

The Models 5011 and 5011-HT Piezoelectric Accelerometers are excellent units for high-level vibration or shock studies. The unique design of the piezoelectric seismic system ensures that the units have no discernible spurious response to mounting torque, body strains, cable vibration, cable whip, pressure variations and most heat transients.

The units incorporate a shear crystal-mass assembly, which ensures that the sensor is insensitive to environmental inputs such as base bending and thermal transients. The sensing element is electrically isolated internally from case ground by means of an inner housing to reduce spurious pickup of ground loop currents. These sensors feature a 10-32 top connector and are provided with a 10' low-noise coaxial cable. The Model 5011-HT will operate in environments up to +500 Deg. F. *Consult the factory for customized versions of these sensors.*

Specifications

Transfer / Electrical	5011 & 5011-HT
Charge Sensitivity ¹	4.5 +/-1.0 pC/g
Capacitance	450 +/-60 pF
Frequency Linearity ²	+/-5% Max 2 Hz To 12,000 Hz
Mounted Resonant Frequency	60 KHz, Nom.
Transverse Sensitivity	5% Max
Amplitude Linearity	+/-1.0% (BFSL) / 500 g
Insulation Resistance	20,000 M Ohm Min, 50 VDC Test
Isolation Resistance	100M Ohm Min.
Environmental	
Vibration Limit	1,000 g Max (Sine)
Shock Limit	5,000 g Max
Temperature Range	
Model 5011	-100 To +350 Deg F (-73 To +175 Deg C)
Model 5011-HT	-100 To +500 Deg F (-73 To +260 Deg C)
Humidity ³	0 To 98% R.H. (Non-Condensing)
Base Strain Sensitivity	0.003 g/uE Equiv, Typical
Electromagnetic Sensitivity	0.01 g (Equiv / 100 Gauss)
Physical	
Configuration	Shear
Size	0.500 In. Hex x 0.550 In. H (12.7 mm Hex x 14.0 mm H)
Weight	0.39 Oz (11 Gm)
Case Material	18-8 Stainless Steel
Electrical Interface	Coaxial 10-32 Thread
Mounting	10-32 Tapped Base

NOTES:

¹ At +75 Deg F, 10g Peak, 100Hz; Lower Frequency Limit is Determined by Associated Electronics

² Referenced to Sensitivity @ 100 Hz.

³ With Connector Protected or Sealed, Unit is Epoxy Sealed

Columbia Research Laboratories, Inc. 1925 Mac Dade Blvd. Woodlyn, PA 19094
Phone: 1.800.813.8471 / Fax: 610.872.3882 / email: sales@columbiaresearchlab.com