



Dynamic Pressure Sensors

Model 765M30 765M35

The Models 765M30 and 765M35 High Intensity Acoustic Sensors (Microphones) are designed for the measurement of gas-borne sound in industrial applications. These sensors have been constructed for use in corrosive environments that are compatible with the type 316 stainless steel diaphragm. The electrically-isolated, coaxial stainless steel hermetic connector, when combined with the all-welded construction, provides a true hermetic seal.

Electrically, the Models 765M30 and 765M35 comprise sensing elements of piezoceramic material in a balanced and floating configuration to provide enhanced rejection of electrical noise associated with many industrial environments. An internal accelerometer provides cancellation of the acoustic element's inherent acceleration sensitivity. Optimum performance is achieved when used with a true differential input amplifier. *Consult the factory for customized versions of this sensor.*

- High Sensitivity (2100 pC/psi)
- High Temperature To +500 Deg F
- Electrically Isolated
- Vibration Compensated

Specifications

Transfer / Electrical	765M30	765M35
Charge Sensitivity	2100 +/-300 pC/psi	
Frequency Response	2 Hz To 8,000 Hz	
Dynamic Range	0.28 x 10 ⁻⁴ to 10 psi (191 dB SPL Max.)	
Vibration Sensitivity	1.0 pC/g Typical, 2.0 pC/g Max.	
Avg Temp Coeff of Sensitivity	0.08% / Deg F	
Transducer Capacitance	14,500 pF +/-15%	
Insulation Resistance	100 Megohms Min., 50 VDC Test	
Isolation Resistance	100 Megohms Min., 50 VDC Test	
Dielectric Strength	550 Vrms, 60 Hz, Element to Housing	
Environmental		
Vibration Limit	100 g Max. (Sine)	
Shock Limit	1,000 g Max., 0.25 mSec	
Temperature Range	-10 To +500 Deg F (-23 To +260 Deg C)	
Humidity ³	0 To 100% R.H.	
Static Pressure	3,000 psi Max. (Diaphragm)	
Electromagnetic Sensitivity	0.005 g (Equiv / 100 Gauss)	
Physical		
Configuration	Balanced Floating Compression	
Size	1.375 In. Hex x 2.25 In. H (35.0 mm Hex x 57.2 mm H)	
Weight	7.0 Oz (200 Gm)	
Material	Type 316 Stainless Steel	
Body & Diaphragm	Type 316 Stainless Steel	
Electrical Interface	Isolated 10-32 Coaxial Connector	Isolated 10-32 Coaxial Connector Supplied with 1/2-14 NPSM Straight Pipe Thread for Armored Shielding
Mounting	1.125 – 12 UNF-2A Straight Thread	

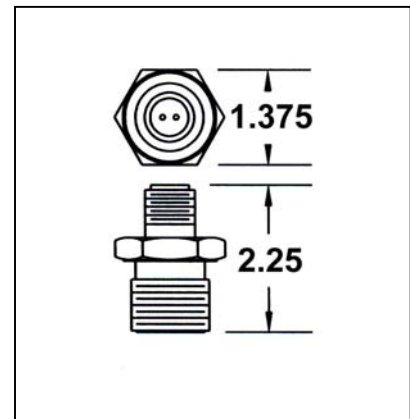

Accessories Supplied:

- (1) Low Noise Cable Assembly (3M) (300 pF)
- (1) Hardwood Storage Case
- (1) Standard Calibration Data

NOTES:

¹ With Connector Mated or Protected, Unit is Hermetically Sealed.