



Dynamic Pressure Sensors

Models 939M10 939M12

The Columbia Series 939 High Intensity Acoustic Sensor (Microphone) is designed for the measurement of gas-borne sound in the frequency range of 2 Hz to 15KHz in industrial applications requiring operation up to +500 Degrees Fahrenheit. These units are constructed for use in corrosive environments which are compatible with the type 316 stainless steel diaphragm. The miniature 10-32 fused-glass coaxial connector combined with the all-welded construction provides a true hermetic seal.

Electrically, the Series 939 transducers comprise sensing elements of piezoceramic material, the low side of which are electrically common with the stainless steel housing. *Consult the factory for customized versions of this sensor.*

- High Sensitivity
- Wide Frequency Response
- High Temperature To +500 Deg F
- Choice of Pipe Thread or Straight Thread Mounting

Specifications

	939M10	939M12
Transfer / Electrical		
Charge Sensitivity	1200 +/-200 pC/psi	
Frequency Linearity	+/-6 dB, 2 Hz To 15,000 Hz	
Dynamic Range	0.10 x 10 ⁻⁴ To 10 psi	
Avg Temp Coeff of Sensitivity	0.08% / Deg F	
Transducer Capacitance	12,000 pF +/-10%	
Insulation Resistance	100 Megohms Min., 50 VDC Test	
Isolation Resistance	0 (Case Grounded)	
Dielectric Strength	550 Vrms, 60 Hz, Element to Housing	
Environmental		
Vibration Limit	100 G Max. (Sine)	
Shock Limit	2,000 G Max., 0.25 mSec.	
Temperature Range	-10 To +500 Deg F (-23 To +260 Deg C)	
Humidity ¹	0 To 100% R.H.	
Static Pressure	550 psi Max. (Diaphragm)	
Electromagnetic Sensitivity	0.005 g (Equiv / 100 Gauss)	
Physical		
Configuration	Single-Ended Compression	
Size	1.375 In. Hex x 1.5 In. H (35.0 mm Hex x 40.6 mm H) 0.750 In. Dia. x 0.09 In. H (Diaphragm) 1 In. NPT Pipe Plug (Body)	1.375 In. Hex x 1.5 In. H (35.0 mm Hex x 40.6 mm H) 0.750 In. Dia. x 0.09 In. H (Diaphragm) 1.125-12 UNF-2A Straight Thread
Weight	8.0 Oz (225 Gm)	
Material	Type 316 Stainless Steel	
Electrical Interface	#10-32 Coaxial Thread	
Mounting	1 In. NPT Male Pipe Thread	1.125 – 12 UNF-2A Straight Thread

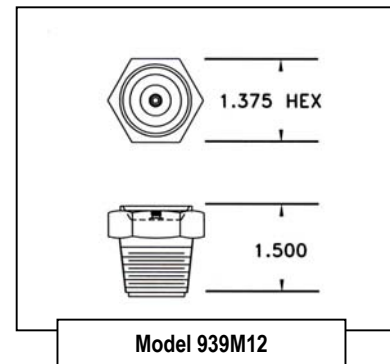

Accessories Supplied:

- (1) Low Noise Cable Assembly (3M) (300 pF)
- (1) Hardwood Storage Box
- (1) Standard Calibration Data

NOTES:

¹ With Connector Mated or Protected, Unit is Hermetically Sealed.